

Great handling



Single Wheel Lift solves lifting and re-treading problems associated with large vehicle tyres.

It has a maximum working load of 125kg with an optional MWL upgrade available.

The roll-on/roll-off platform and easy to operate locking device create the ideal tool for re-grooving tyres, outside the vehicle, or inside, away from the elements.

Features

- Maintains unhindered access
- Hydraulically powered for a smooth controlled operation
- Side and rear door applications
- Minimal impact on vehicle payload
- Remote and static controls
- Roll-on/roll-off platform
- Hydraulic overload protection
- Standard 125kg MWL

Options

- Radio remote control
- Bespoke platform size
- Upgrade to 350kg MWL
- Re-grooving clamp
- Battery protection

Applications

- Highways
- Construction
- Utilities
- Railways
- Tyre industry

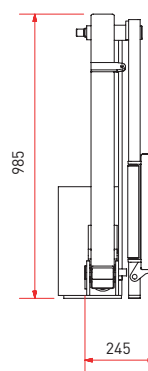
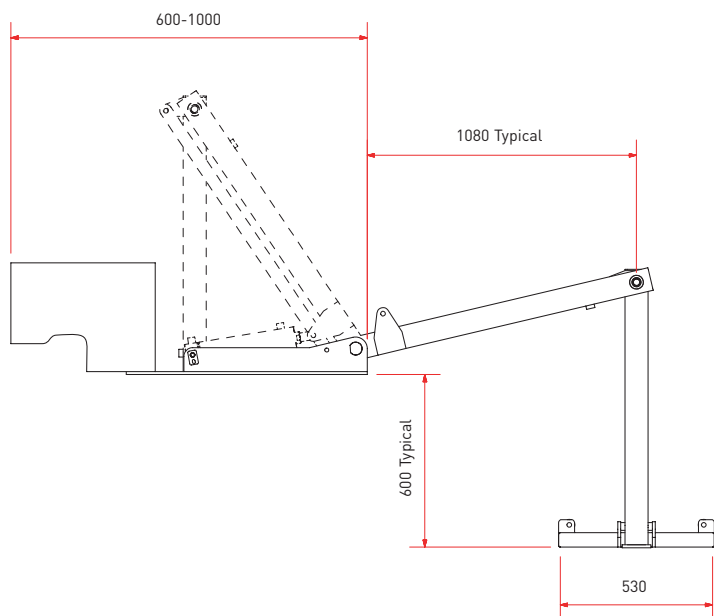

Weights & measurements

Total self weight 60-100kg