



Roadside assistance

Designed for 3.5 to 17 tonne vehicles, SideLift 250 enables deliveries to be made directly onto the kerbside, dramatically reducing the space required to park and enabling more even distribution of the load, thereby reducing route planning time and risks of axle overload.

Features

- Hydraulically powered for a smooth controlled operation
- Easy installation, no welding required
- 12v or 24v versions available
- Minimal reduction in vehicle payload
- Handles loads up to 250kg
- Remote and static controls
- In cab isolator and warning buzzer
- Hydraulic overload protection

Options

- Radio remote control
- Off-set platforms
- Battery protection



Applications

- Highways
- Construction
- Utilities
- Local authorities
- Tyre industry

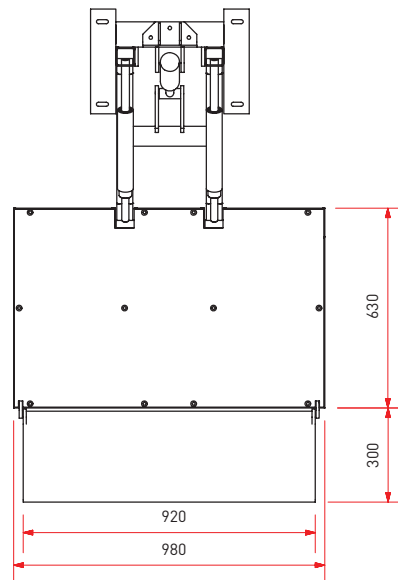
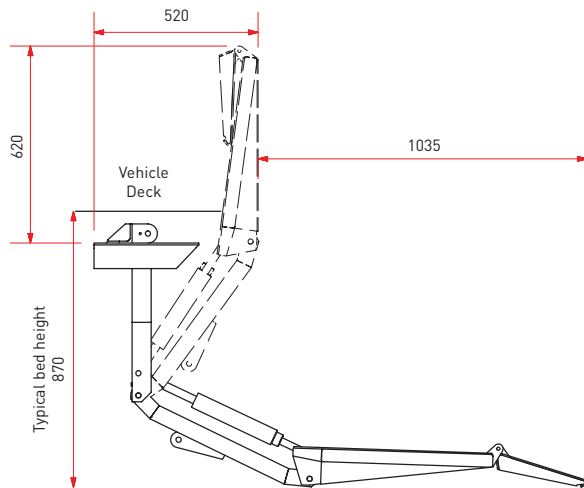

Weights & measurements
Total self weight 95kg