

For maximum flexibility



Specially designed to be fitted to any vehicle these knuckle-joint cranes offer complete flexibility allowing loads to be positioned accurately anywhere within their radius. Available with a 1 or 1.5 metre radius.

Features

- Lifts up to 250kg – ideal for gas bottles and small items of plant
- Overload device – will not lift more than MWL
- Low crane weight of approximately 31-34kg
- Compact design maximising vehicle floor space
- Fully demountable – can be deployed on other vehicles or removed altogether, therefore maintaining maximum fleet flexibility
- Can be re-fitted to new replacement vehicles
- Easy to operate one-man operation with minimal moving parts
- Easy to maintain and with long service intervals

Options

- Bespoke boom length to suit application
- 100kg and 150kg versions also available
- 12v or 24v operation from vehicle battery
- Radio remote control
- Corner bracket for mounting direct to a pick-up vehicle headboard
- Cranked hinge available allowing even greater flexibility
- Additional pillar height
- Extra rope length – 9m/30' up to 250kg
- Battery protection
- Lifting accessory kit



Applications

- Highways
- Construction
- Utilities
- Fire & rescue

KJ250/1

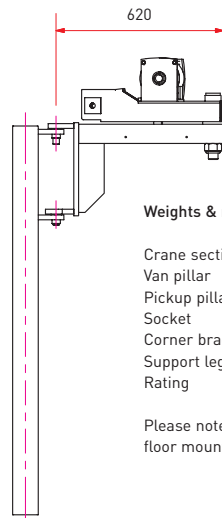
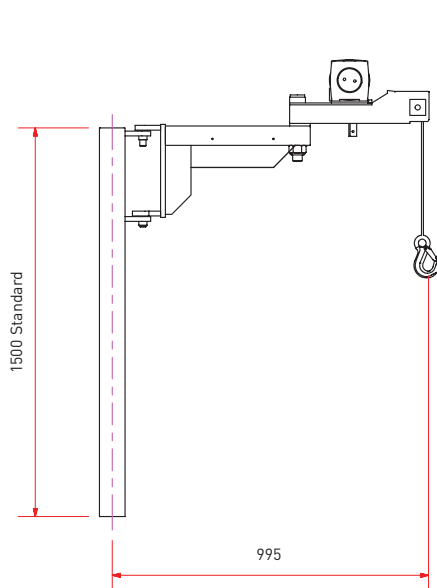

Weights & measurements

Crane section	31kg
Van pillar	25kg
Pickup pillar	18kg
Socket	17kg
Corner bracket	5.5kg
Support leg	8kg
Rating	0.25 tonne metres

Please note that an above or below floor mounting socket is available.

KJ250/1.5

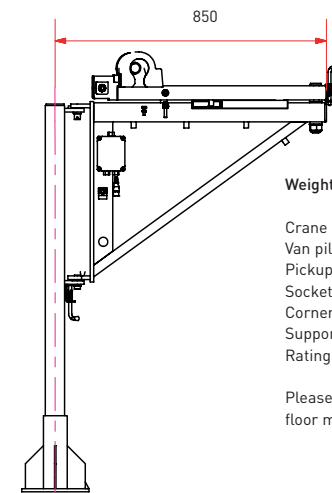
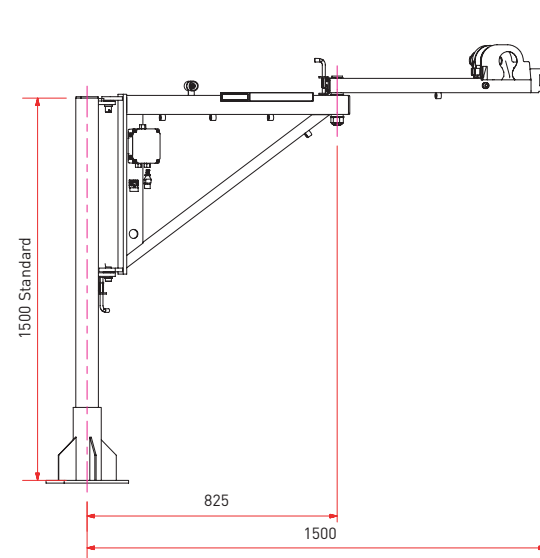

Weights & measurements

Crane section	34kg
Van pillar	25kg
Pickup pillar	18kg
Socket	17kg
Corner bracket	5.5kg
Support leg	8kg
Rating	0.375 tonne metres

Please note that an above or below floor mounting socket is available.